



TOWN OF DOVER

MAYOR AND BOARD OF ALDERMEN

Date of First Reading 6/24/08

Date of Public Hearing
Second Reading 7/08/08

Ordinance No. 17-2008

An ordinance of the Mayor and Board of Alderman of the Town of Dover, County of Morris and the State of New Jersey amending **Chapter 236, LAND USE AND DEVELOPMENT, ARTICLE IV, Zoning**, of the Code of the Town of Dover.

BE IT ORDAINED by the Mayor and Board of Alderman of the Town of Dover, County of Morris and state of New Jersey as follows:

Section 1

Chapter 236, LAND USE AND DEVELOPMENT, ARTICLE IV, Zoning, is supplemented with the following:

236-38.1 Signage, Awnings and Canopies in the C-1 and C-3 Districts

A. Signage

All signs shall comply with general sign provisions set forth in Section 236-38. A. through L. of the Town's Code except as specifically modified herein. If there is any conflicting standard, the standards set forth herein shall prevail. Nothing herein shall prevent the Historic Preservation Commission from making additional requirements as part of the Certificate of Historic Review process for those properties that lie in the Blackwell Street Historic Preservation District.

- (1) General Requirements. Where a building requires several different signs, they shall be thematically linked and shall be similar in materials, color and method of lighting. Internally illuminated signs are not permitted. The maximum gross area of all signs on a given façade shall not exceed 32 square feet.
- (2) Wall Signs. Each nonresidential use located on the ground floor and having a street level entrance along a public sidewalk may install wall signage in accordance with all of the following requirements:
 - (a) The maximum quantity of wall signs for each ground floor business use shall be no more than one (1) wall sign per street frontage.
 - (b) The sign shall be located on the wall area situated near the main public entrance or centered along the street frontage.
 - (c) The maximum height from ground-level to uppermost portion of the sign shall not exceed the height of the sill or bottom of any second story window or sixteen (16) feet, whichever is less. In the case of single-story buildings, the maximum height shall not exceed fourteen (14) feet or the top of the wall face, whichever is less.
 - (d) The minimum height from ground-level to lowermost portion of the sign shall be no less than eight (8) feet.
 - (e) Maximum permitted sign area shall be no greater than one square-foot per lineal foot of building frontage occupied by the use on that particular building frontage, not to exceed 24 (24) square feet.
 - (f) Maximum permitted horizontal sign dimension (width) shall be no greater than seventy-five percent (75%) of the width of the building frontage occupied by the use on that particular building frontage, not to exceed eighteen (18) feet.

TOWN OF DOVER
MAYOR AND BOARD OF ALDERMEN

- (g) Maximum vertical dimension (height) of the sign face shall not exceed two (2) feet.
 - (h) No wall sign shall project more than eight (8) inches from the wall face upon which it is attached.
 - (i) The sign shall only be externally or indirectly illuminated.
- (3) Parking Garage Signs. Wall signs identifying an entrance of a parking garage may be permitted but shall be in conformance with regulations set forth above for wall signs.
- (4) Awning Signs. Non-residential uses located on the ground floor may display signs on awnings, provided that the following standards are met:
- (a) Awning signs shall only be permitted on first-story awnings that provide roof-like shelter and/or solar shielding above doorways and windows.
 - (b) The dimensions of the awning shall be in conformance with applicable regulations set forth elsewhere herein for awnings.
 - (c) The sign shall only be located on the front portion of the awning that is generally parallel to the building wall face to which it is attached. This portion is more commonly known as the “valance” (see Figure 1). In the case of an awning shape where a traditional valance might not be provided, the sign text and graphic characters shall be restricted to the lowest fourteen (14) inches of the awning, which must be shown to be nearly parallel to the building wall face. In the case of dome awnings, the sign graphics shall additionally be restricted to the middle one-fifth (1/5th) of the awning, when viewed from the front elevation, which must be shown to be nearly parallel to the building wall face.
 - (d) All awning signs shall be professionally sewn or painted.
 - (e) The maximum vertical dimension of the sign face (valance) shall not exceed fourteen (14) inches.
 - (f) The maximum height of letters, individual numbers or other characters or images on the awning shall not exceed twelve (12) inches.
 - (g) Maximum width of individual letters, numbers, or other characters or images on the awning shall not exceed eighteen (18) inches.
 - (h) The total aggregate horizontal dimension (width) of all individual letters, numbers or other characters shall not exceed twenty (20) feet, or seventy-five (75%) of the width of the awning, as viewed in front elevation, whichever is less.
 - (i) The awning shall be limited to a total of two (2) colors plus white as approved by the Planning Board, including the color of sign lettering and all other graphics (see Figure 1).
 - (j) No single awning shall contain sign messages for more than two (2) business establishments.
 - (k) The maximum quantity of awning signs for each nonresidential use located on the ground floor shall be no more than two (2) awning signs per street frontage.
 - (l) Awning signs shall not be internally illuminated.

TOWN OF DOVER

MAYOR AND BOARD OF ALDERMEN

Figure 1 – Awning Signs

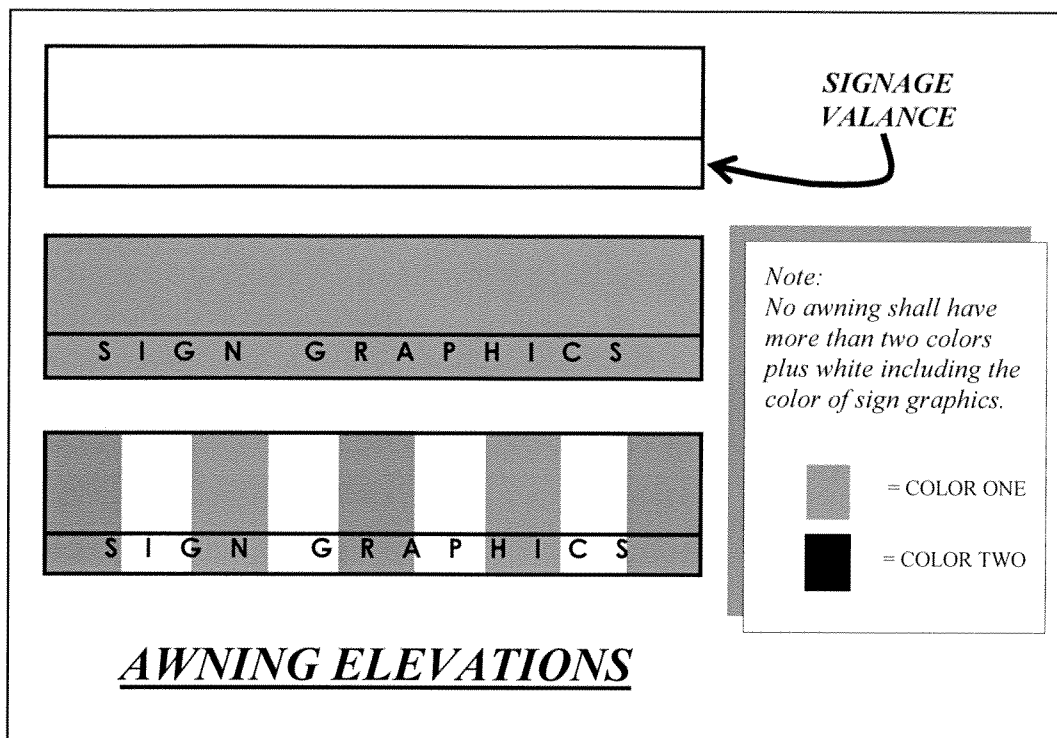

- (5) Permanent Window Signs. Only retail or personal service business uses located below the third story of a building shall be permitted to display a permanent window sign. Such sign may be professionally painted on the interior side of a window or may consist of a professionally printed permanent decal(s) installed on the interior side of a window, provided that the following standards are complied with:
- (a) No window sign shall be permitted in a window above the second-story of a building.
 - (b) Maximum area of any and all such sign shall not exceed twenty-five percent (25%) of the total window area, not to exceed six (6) square feet in area per window.
 - (c) One (1) sign per business establishment per window shall be permitted, up to a maximum of two (2) signs per business on any wall frontage.
 - (d) The sign(s) shall be limited to the name and/or type of business, the address and phone number.
 - (e) The sign(s) may be internally illuminated.
- (6) Wall-mounted Directory Sign. For buildings containing non-residential tenant(s) located above the ground level, one (1) wall-mounted directory sign for each ground floor public entrance into a building shall be permitted whether such entrance fronts on a street or a parking lot.
- (a) The maximum size of the wall-mounted directory sign shall not exceed eight (8) square feet in sign area.
 - (b) The maximum height from the ground-level to uppermost portion of the sign shall not exceed nine (9) feet if situated directly above the doorway entrance, or six (6) feet if not situated directly above the doorway entrance.

TOWN OF DOVER
MAYOR AND BOARD OF ALDERMEN

- (c) The minimum height from ground-level to lowermost portion of the sign shall be no less than two (2) feet.
 - (d) Such sign may identify all building occupant names and their addresses, however, no sign message for an individual business shall occupy greater than six (6) square feet in area of such a sign.
 - (e) A wall-mounted directory sign may only be externally illuminated with a shielded fixture.
 - (f) All lettering on a wall-mounted directory sign shall be of the same type-face (font) style.
- (7) Projecting Sign. Each nonresidential use located on the ground floor and having a direct street level entrance may install one (1) projecting sign subject to the following:
- (a) The sign shall be attached to the wall along the frontage such use occupies.
 - (b) Such sign face and all signage must be oriented in a position that is perpendicular to the wall to which it is attached.
 - (c) No such sign shall have a thickness that exceeds eight (8) inches.
 - (d) Maximum size of each sign face shall not exceed six (6) square feet in area.
 - (e) Minimum height from ground level to lowermost portion of sign shall be no less than nine (9) feet.
 - (f) Maximum height from ground level to uppermost portion of sign shall not exceed the height of the sill or bottom of any second story window or sixteen (16) feet, whichever is less. In the case of single-story buildings, said maximum height shall not exceed fourteen (14) feet or the top of the wall, whichever is less.
 - (g) Maximum horizontal projection from the building wall, including any sign appurtenances, shall not exceed three (3) feet. Such sign may project over a public sidewalk only and shall not extend over any other portion of any other public right-of-way.
 - (h) Maximum horizontal dimension (width) of the sign face shall not exceed three and one-half (2 ½) feet.
 - (i) Maximum vertical dimension (height) of the sign face shall not exceed four (4) feet.
 - (j) Maximum height of letters, individual numbers or other characters or images on the signboard shall not exceed twelve (12) inches.
 - (k) Maximum width of letters, individual numbers or other characters or images on the signboard shall not exceed twelve (12) inches.
 - (l) A projecting sign may be internally or externally illuminated.
- (8) Temporary Window Advertising Signs. Temporary window advertising signs for ground level retail and personal service business uses located in the C-1 and C-3 Districts are exempt from approval requirements, subject to the following conditions:
- (a) Such signs may be constructed of paper, cardboard or plastic, and any written, numerical, graphic or photographic material or information shall constitute such a sign.

TOWN OF DOVER
MAYOR AND BOARD OF ALDERMEN

- (b) Such signs shall be removed after a period of thirty (30) days and shall have the date of installation printed clearly in the lower right-hand corner of such, as viewed from the exterior.
 - (c) Such signs shall be contained solely within the ground level window of the subject business.
 - (d) Maximum total area of such signs shall not exceed 40% of the total area of ground level windows, excluding window portions of doors, fronting on a public street. For the purposes of this subsection, any window area covered with a permitted permanent window sign, pursuant to this article, shall be excluded from the calculation of the total area of all ground floor windows.
 - (e) Information on such signs shall be limited to advertisements for special promotions, temporary sales and other such similar nonpermanent sales promotions for the permitted business conducted on the premises on which said sign is located.
 - (f) Such signs shall be maintained in an orderly manner at all times.
 - (g) This section shall not be interpreted in such a manner as to limit or prohibit any business from displaying merchandise in an interior window display area.
- (9) Portable Sidewalk Sign. Only retail and personal service business uses and eating and drinking establishments shall be permitted to display sandwich board signs and other types of portable signs, subject to the following conditions:
- (a) Maximum size of such signboard shall not exceed five (5) square feet in area. If such sign is two-sided, only one (1) side of such shall be used for the purpose of calculating the permitted sign area.
 - (b) Maximum height and width of letters, numbers or other characters or images on the signboard shall not exceed twelve (12) inches.
 - (c) Such signs shall be located within four (4) feet of an entrance to the business they advertise and shall not be placed so as to interfere with pedestrian or vehicular traffic on a street, sidewalk, walkway or public right-of-way. An unobstructed pathway of at least four (4) feet in width must be maintained on a sidewalk at all times.
 - (d) Such signs shall be constructed of wood, slate board and/or finished metal.
 - (e) Information contained on such signs shall be limited to advertisements for special promotions, sales and other such similar non-permanent sales promotions for the permitted business conducted on the premises adjacent to which said sign is located.
 - (f) Such signs shall be maintained in an orderly manner at all times.
 - (g) In a building with multiple business occupants who share a common entrance, no more than two (2) such signs shall be permitted, which may be shared among the applicable businesses entitled to a portable special promotion sign under the provisions of this section.
 - (h) Any business use that places or installs such sign, pursuant to this section, shall be required to conform to all other applicable provisions of this article, otherwise, such business shall be prohibited from displaying such sign.
 - (i) No such sign shall be displayed when the business it relates to is not open for business.
 - (j) Such signs shall not be illuminated.
- (10) Freestanding and Ground Signs. Freestanding and Ground signs are not permitted.

TOWN OF DOVER

MAYOR AND BOARD OF ALDERMEN

- (11) Residential Use Signage. Signage pertaining to residential uses shall be in accordance with the signage requirements set forth in the Town's Code for residential uses.

B. Awnings and Canopies

Awnings and canopies are encouraged in the C-1 and C-3 Districts at the street level of a building when occupied by a nonresidential use. For all uses, awnings and canopies may be used on the upper floors of a building, where appropriate. The design of awnings and canopies shall be architecturally compatible with the style, materials, colors and details of such buildings and should not conceal significant architectural features, such as cornices, columns, pilasters or other trim details. Nothing herein shall prevent the Historic Preservation Commission from making additional requirements as part of the Certificate of Historic Review process for those properties that lie in the Blackwell Street Historic Preservation District. All of the following standards for street-level awnings and canopies shall additionally apply:

1. The highest point of a street-level awning or canopy shall not extend above the top of the first-story windows by more than four (4) feet or fourteen (14) feet above the sidewalk grade elevation, whichever is less.
2. The minimum height clearance between the sidewalk and the lowest point of an awning or canopy shall be no less than seven feet six inches (7'-6").
3. The maximum horizontal projection dimension of an awning from the building wall, including any appurtenances, shall not exceed six (6) feet from the building face. Awnings may project over a public sidewalk but shall not be closer than two (2) feet to the vertical plane of the curb line or the edge of any other public right-of-way.
4. No permanent canopy structure with a projection greater than eight (8) inches from the building wall face shall project over a public right-of-way (including a public sidewalk), unless approved by the governing body of the Town.
5. When fully extended and viewed in side elevation, the height dimension of an awning shall not exceed the projection from the wall face (see Figure 2 below).
6. The surfacing material of awnings shall be made of canvas or modern materials that mimic canvas with traditionally dyed colors in solids or stripes. Metal and vinyl awnings are prohibited. Canopies shall be made of materials permitted for awnings or may be made of architectural materials found on the façade of the building.
7. No awning shall contain more than two (2) colors plus white. The color of any sign messages or other graphic features shall be included in the number of colors. The colors must be compatible with the architectural color scheme of the entire building.
8. On buildings with multiple storefronts, coordinating awning and canopy frame styles shall be used as a means of unifying the structure.
9. All signage on awnings shall be in conformance with applicable regulations set forth elsewhere herein for awning signs.
10. All signage mounted, affixed or displayed directly on a fixed-position canopy shall be regulated as wall-mounted signs in accordance with applicable regulations set forth elsewhere herein for wall signs.

TOWN OF DOVER

MAYOR AND BOARD OF ALDERMEN

11. Internally illuminated or backlit awnings and canopies are not appropriate and are therefore strictly prohibited. No awning or canopy shall have illumination which permits the passage of light or allows light to be seen through the surface material of the awning or canopy so as to illuminate the exterior of the awning or canopy.

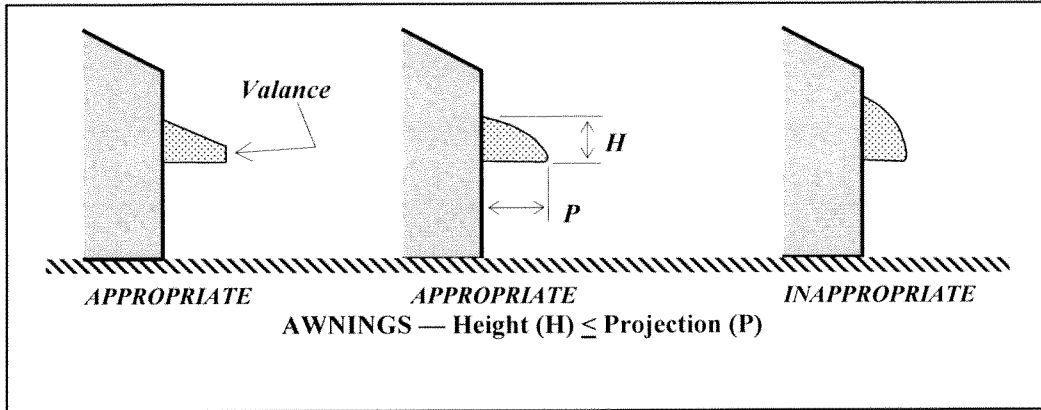

Figure 2 – Awning Proportion

Section 2

All ordinances or parts of ordinances inconsistent with this ordinance are hereby repealed to the extent of such inconsistencies.

Section 3

If any article, section, subsection, paragraph, phrase or sentence is, for any reason, held to be unconstitutional or invalid, said article, section, subsection, paragraph, phrase or sentence shall be deemed severable.

Section 4

This ordinance shall take effect immediately upon final publication as provided by law.

MOVED: Aldermen Picciallo, Romaine

SECONDED: Alderman Timpani, Visioli

Aldermen	AYE	NAY	N.V.	A.B
PICCIALLO	X X			
POOLAS	X			X
DONOFRIO	X X			
ROMAINE	X X			

Aldermen	AYE	NAY	N.V.	A.B
VISIOLI	X			
FAHY				X X
DELANEY	X X			
TIMPANI	X			X
MAYOR DODD	X X			

X - Indicates Vote

A.B. – Absent

N.V - Not Voting (Abstained or Excused)

Tabled _____

Removed from Table _____

Entered on Board of Aldermen Minutes, Page _____

Adopted July 8 2008

Mun. Clerk's Cert. Margaret J. Verge

Mayor [Signature]